

PROJECT: LOT 21732 (GH-01) DRAWING: LOCATION MAP

Scale: N.T.S. Drawn by: Thorif Ibrahim Checked by: Mohamed Ibrahim Date: 27th November 2022 Remarks:

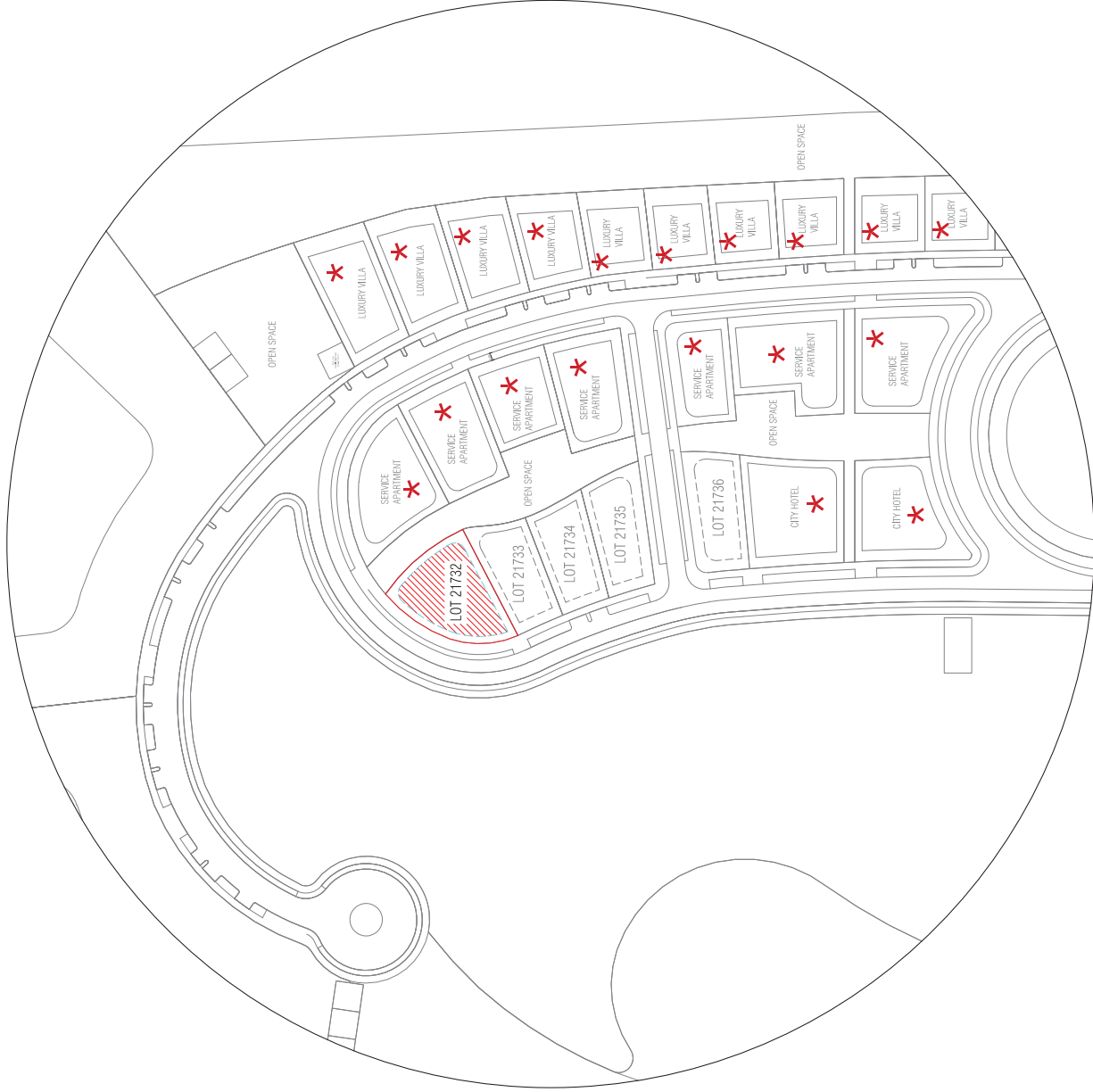



LEGEND:
* PROPOSED

PROJECT: LOT 21732 (GH-01)

Scale: N.T.S

Drawn by: Shadheen

Checked by:

Date: 5th November 2022

Remarks:

DRAWING: SITE CONTEXT PLAN



HOUSING DEVELOPMENT CORPORATION
PLANNING AND DEVELOPMENT DEPARTMENT
3RD FLOOR, HDC BUILDING HULHUMALE,
REPUBLIC OF MALDIVES
TEL: +(960)3358365, FAX: +(960)3358892
EMAIL: planning@hdc.com.mv



E 339088.782
N 468680.773

OPEN / GREEN
SPACE

E 339076.839
N 468673.459

28.08M

E 339063.440
N 468669.386

LOT 21732 (GH-01)
PLOT AREA = 647.16 SQM
(6,965.97 SQFT)

33.07M
LOT 21733

E 339082.989
N 468690.001

21.85M

E 339075.076
N 468697.490

ROAD

E 339066.299
N 468701.311

19.25M

E 339056.735
N 468701.707

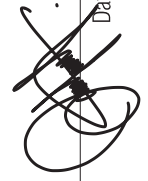

PROJECT: LOT 21732 (GH-01)

Scale: N.T.S

Drawn by: Thorif Ibrahim

Checked by: Mohamed Ibrahim

Date: 27th November 2022

Remarks:

DRAWING: PLOT MAP

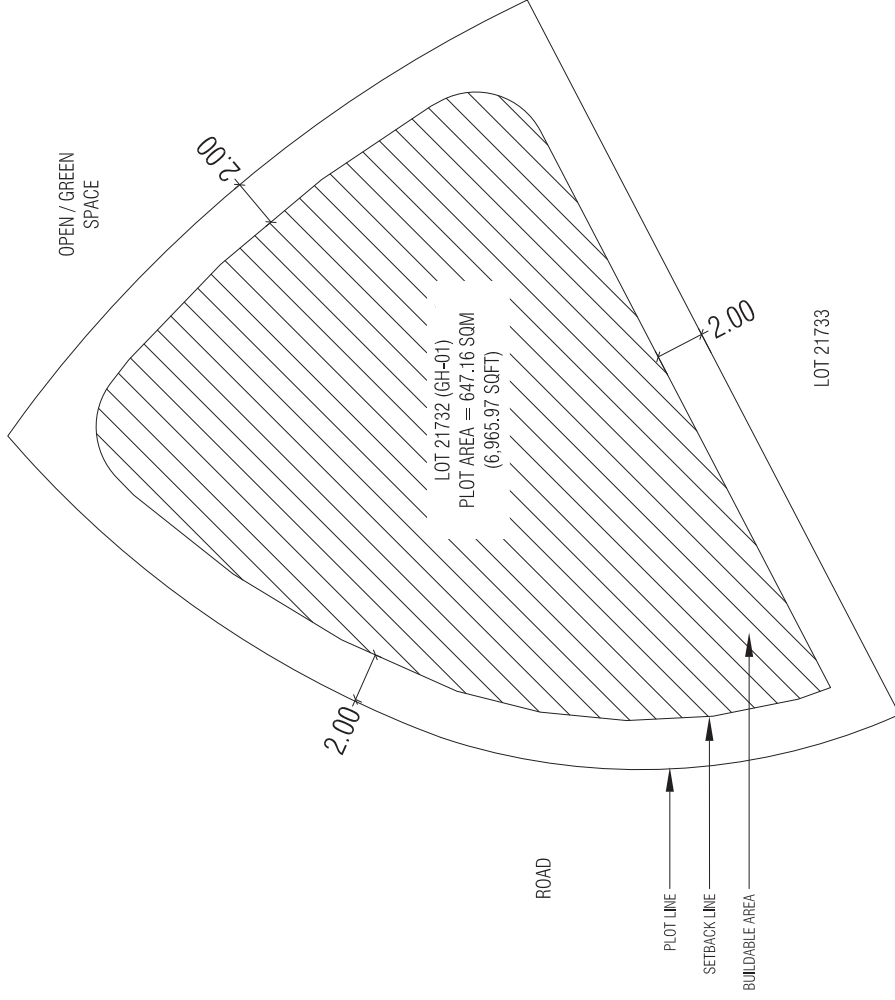

Lot Number	Description	Land Use	Plot Area	Plot Area	Foot Print	Gross Floor Area (G.F.A)	Plot Ratio (F.S.I)	Site Coverage	Max Height / Floors
21732	Guest House	Commercial	647.16 SQM	6,965.97 SQFT	453.01 SQM	2,944.58 SQM	4.6	70%	6 Floors / 22.5 m
					4,876.18 SQFT	31,695.14 SQFT			18.5 m bldg + 4m Lift Machine Room

PROJECT: LOT 21732 (GH-01) DRAWING: SETBACK PLAN

Scale: N.T.S Date: 5th November 2022 Remarks:

Checked by: 

Drawn by: Mauman

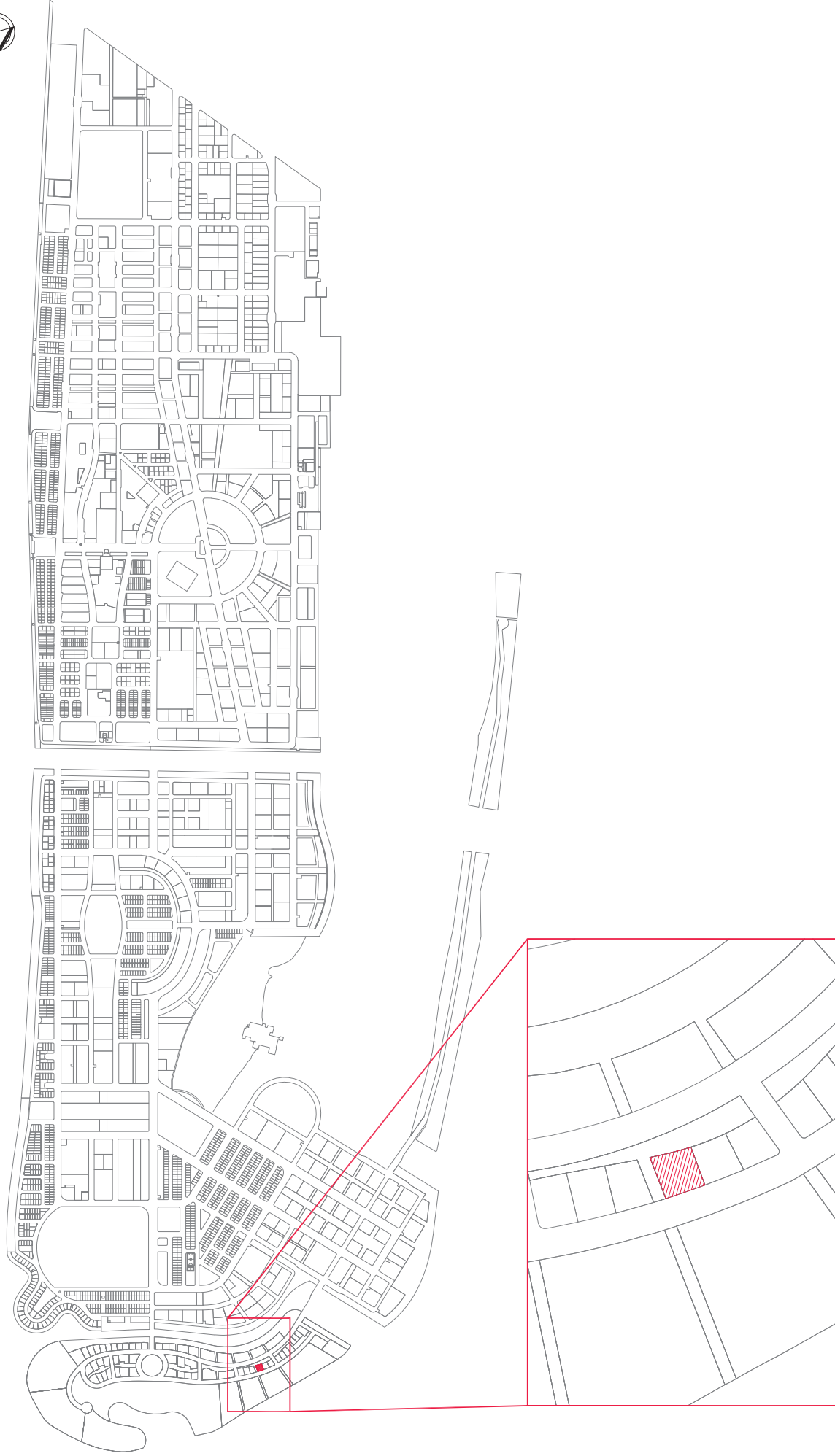

PROJECT: LOT 21742 (GH-11) DRAWING: LOCATION MAP

Scale: N.T.S Date: 27th November 2022



Drawn by: Thorif Ibrahim Checked by: Mohamed Ibrahim

Remarks:



LEGEND:
 * PROPOSED

PROJECT: LOT 21742 (GH-11)

Scale: N.T.S

Drawn by: Shadheen

Checked by:

Date: 5th November 2022

Remarks:

DRAWING: SITE CONTEXT PLAN



HOUSING
 DEVELOPMENT
 CORPORATION
 PLANNING AND DEVELOPMENT DEPARTMENT
 3RD FLOOR, HDC BUILDING HULHUALA,
 REPUBLIC OF MALDIVES
 TEL: +(960)3358926, FAX: +(960)3358992
 EMAIL: planning@hdc.com.mv

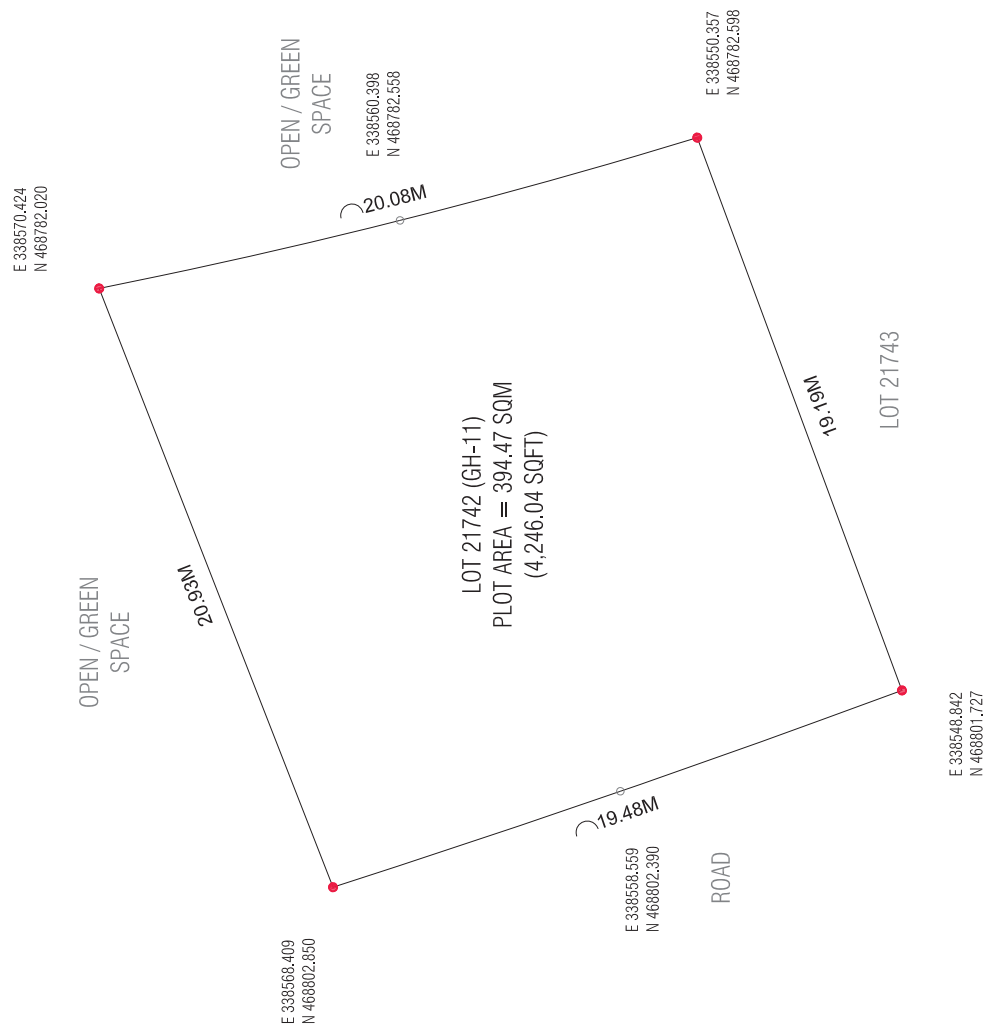

(Signature)

PROJECT: LOT 21742 (GH-11) Drawn by: Thorif Ibrahim Checked by: Mohamed Ibrahim Date: 27th November 2022 Remarks:

Scale: N.T.S

DRAWING: PLOT MAP

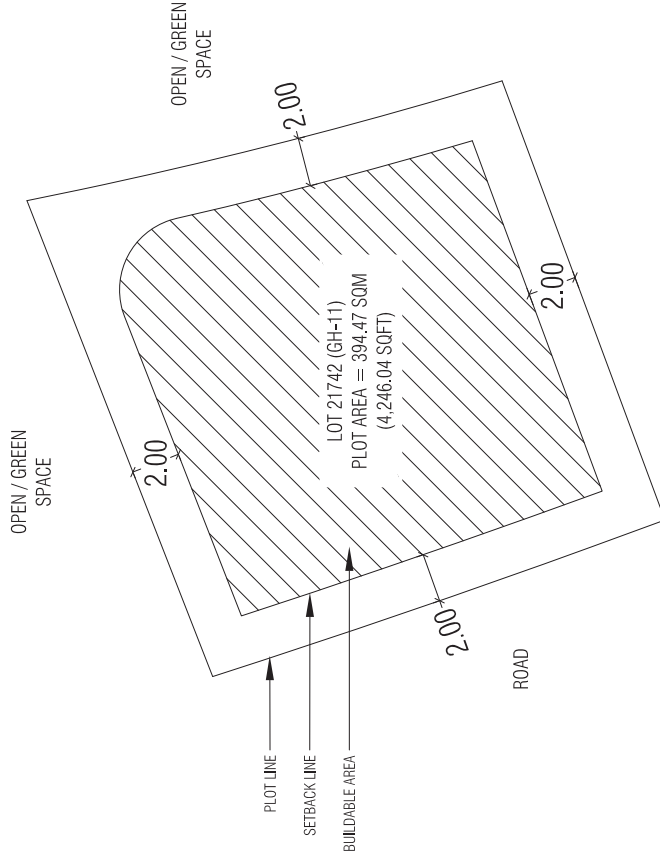

LOT 21743

Lot Number	Description	Land Use	Plot Area	Foot Print	Gross Floor Area (G.F.A)	Plot Ratio (F.S.I)	Site Coverage	Max Height / Floors
21742	Guest House	Commercial	394.47 SQM 4,246.04 SQFT	276.13 SQM 2,972.22 SQFT	1,794.84 SQM 19,319.46 SQFT	4.6	70%	6 Floors / 22.5 m 18.5 m bldg + 4m Lift Machine Room

PROJECT: LOT 21742 (GH-11) DRAWING: SETBACK PLAN

Scale: N.T.S

Drawn by: Mauman

Checked by:

Date: 5th November 2022

Remarks:

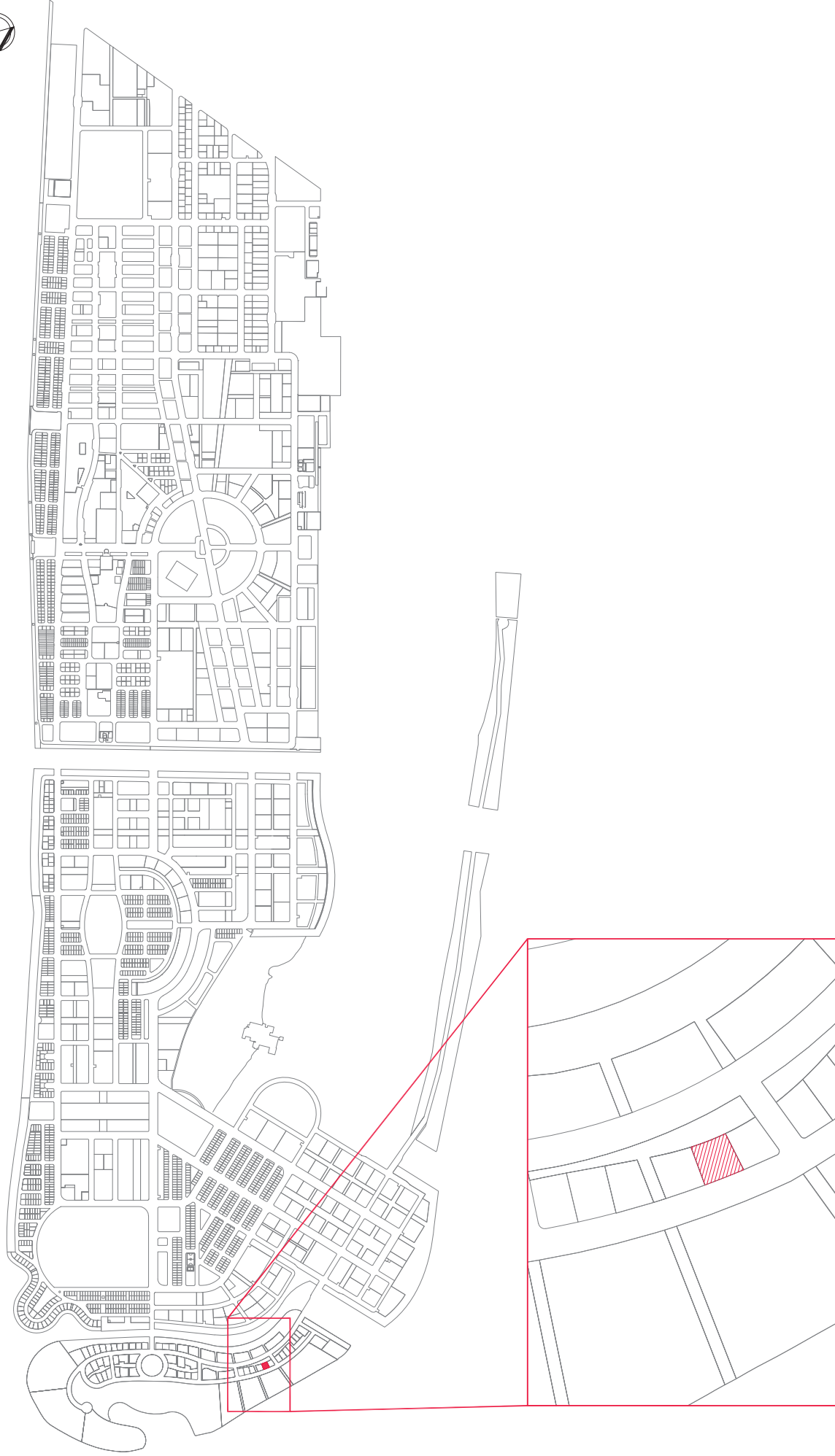

PROJECT: LOT 21743 (GH-12) DRAWING: LOCATION MAP

Scale: N.T.S Date: 27th November 2022

Checked by: Mohamed Ibrahim

Drawn by: Thorif Ibrahim

Remarks:





LEGEND:
 * PROPOSED

PROJECT: LOT 21743 (GH-12)

Scale: N.T.S

Drawn by: Shadheen

Checked by:

Date: 5th November 2022

Remarks:

DRAWING: SITE CONTEXT PLAN



HOUSING
 DEVELOPMENT
 CORPORATION
 PLANNING AND DEVELOPMENT DEPARTMENT
 3RD FLOOR, HDC BUILDING HULHUALA,
 REPUBLIC OF MALDIVES
 TEL: +(960)3358926, FAX: +(960)3358992
 EMAIL: planning@hdc.com.mv

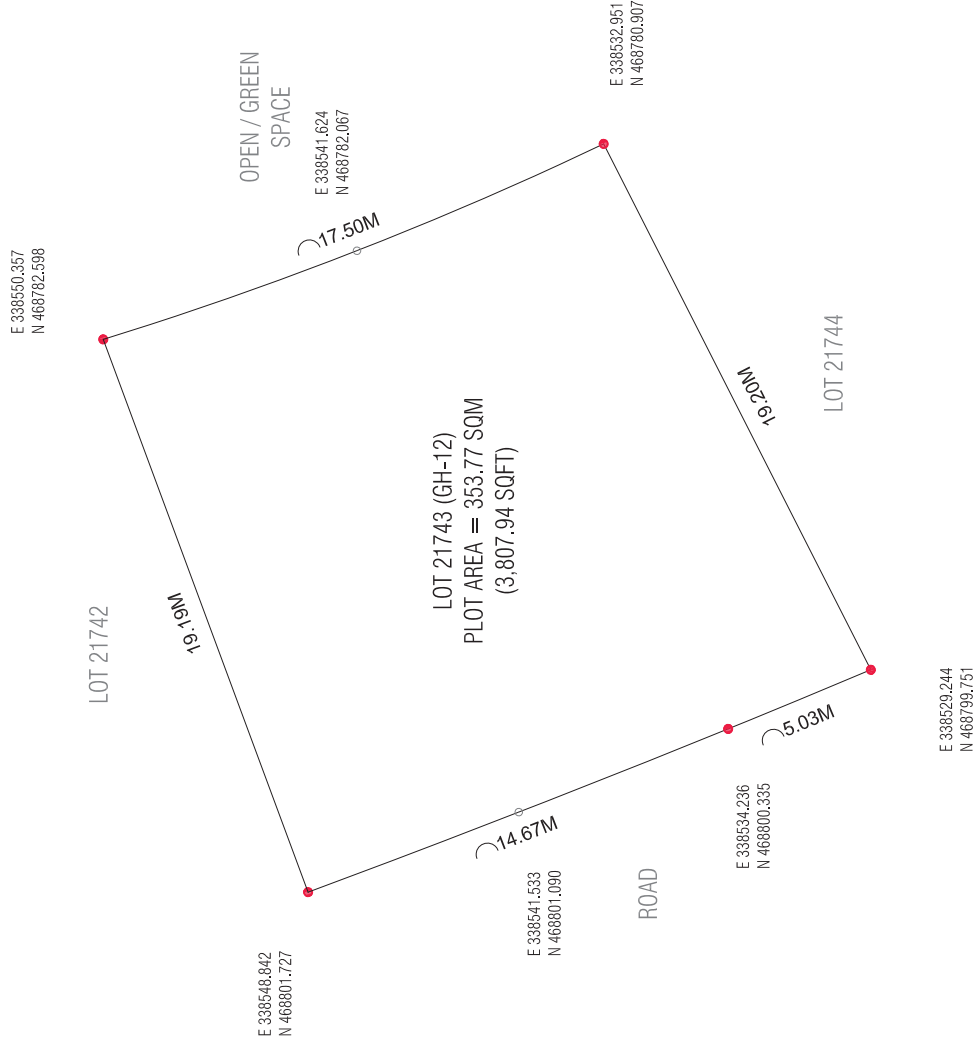

PROJECT: LOT 21743 (GH-12) DRAWING: PLOT MAP

Scale: N.T.S Date: 27th November 2022

Checked by: Mohamed Ibrahim

Drawn by: Thorif Ibrahim

Remarks:

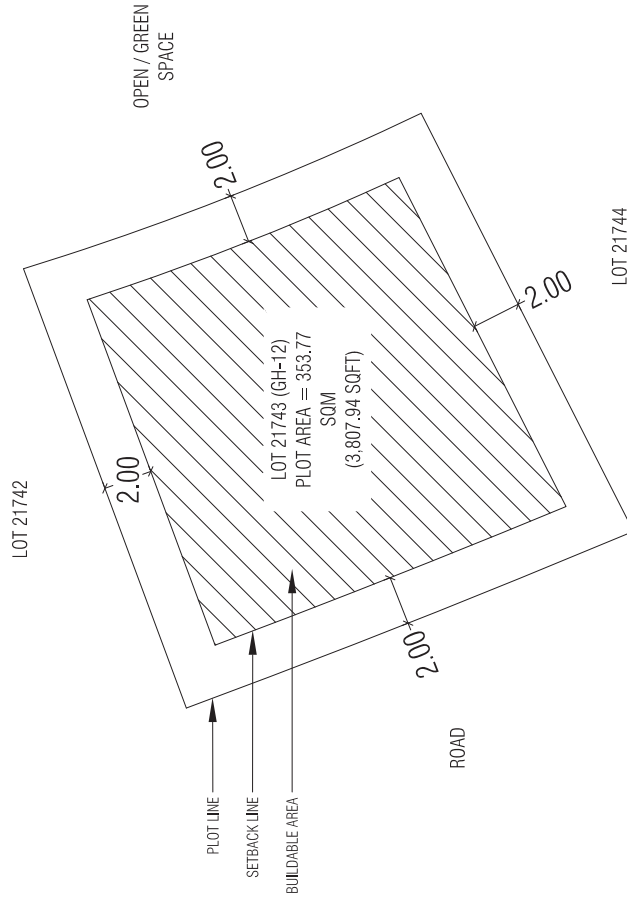

Lot Number	Description	Land Use	Plot Area	Foot Print	Gross Floor Area (G.F.A)	Plot Ratio (F.S.I)	Site Coverage	Max Height / Floors
21743	Guest House	Commercial	353.77 SQM	247.64 SQM	1,609.65 SQM	4.6	70%	6 Floors / 22.5 m
			3,807.94 SQFT	2,665.56 SQFT	17,326.15 SQFT			18.5 m bldg + 4m Lift Machine Room

PROJECT: LOT 21743 (GH-12) DRAWING: SETBACK PLAN

Scale: N.T.S Drawn by: Mauman Checked by: Date: 5th November 2022 Remarks:

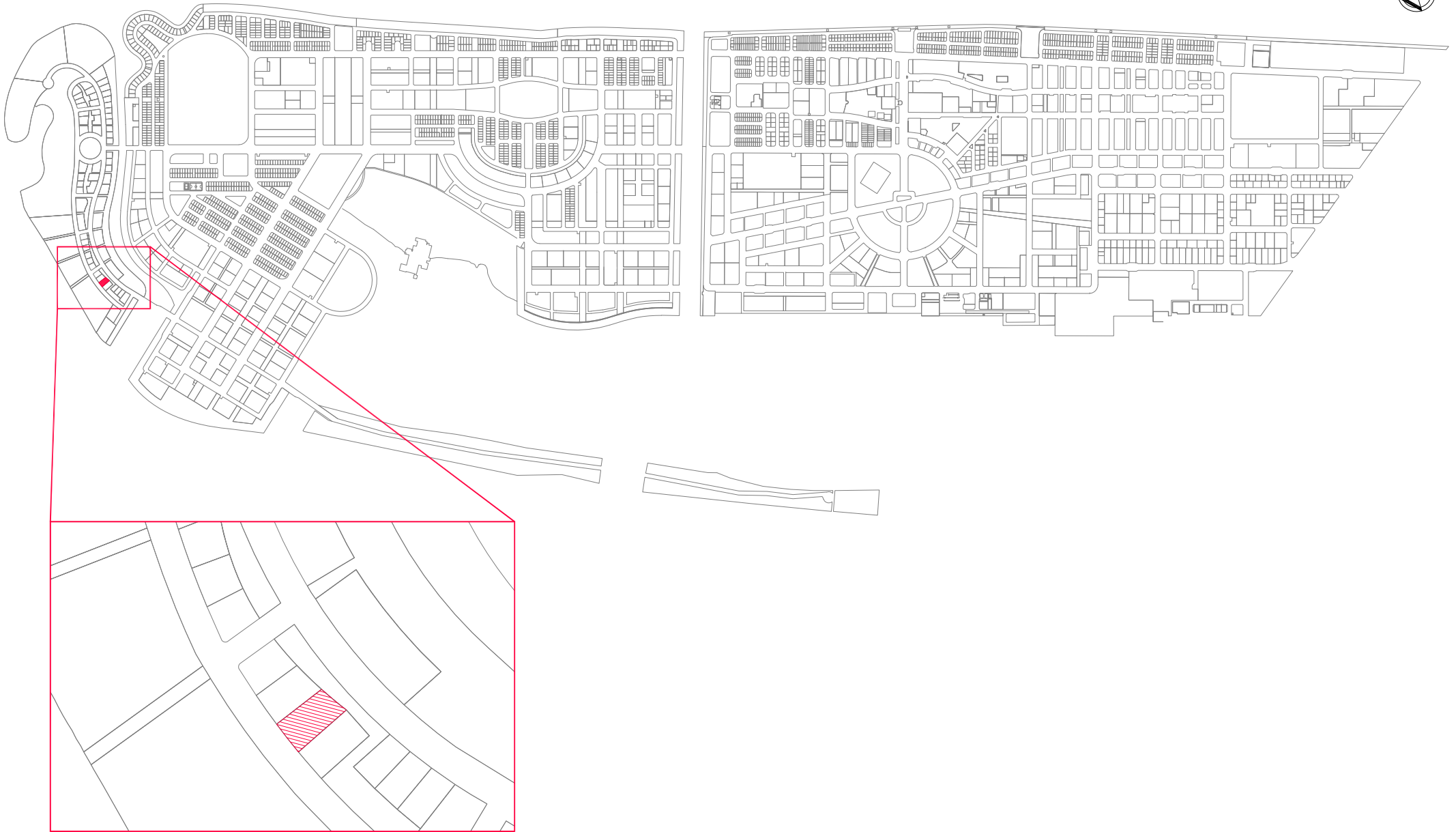

PROJECT: LOT 21747 (GH-16)

Scale: N.T.S

Drawn by: Thorif Ibrahim

Checked by: Mohamed Ibrahim

Date: 27th November 2022

DRAWING: LOCATION MAP

Remarks:



LEGEND:

* PROPOSED

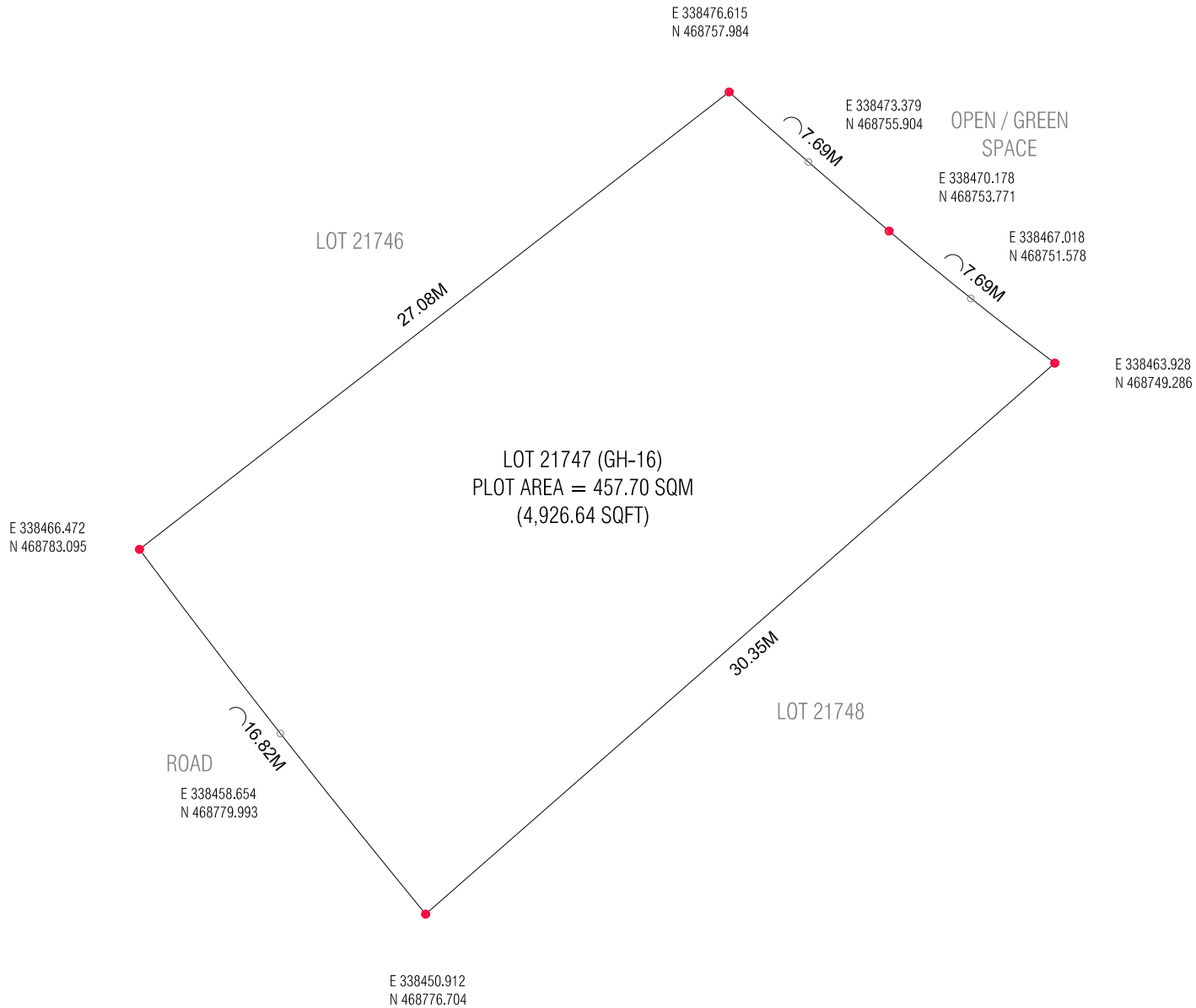

PROJECT: LOT 21747 (GH-16)

Scale: N.T.S

Drawn by: Thorif Ibrahim

Checked by: Mohamed Ibrahim

Date: 27th November 2022

Remarks:

DRAWING: PLOT MAP

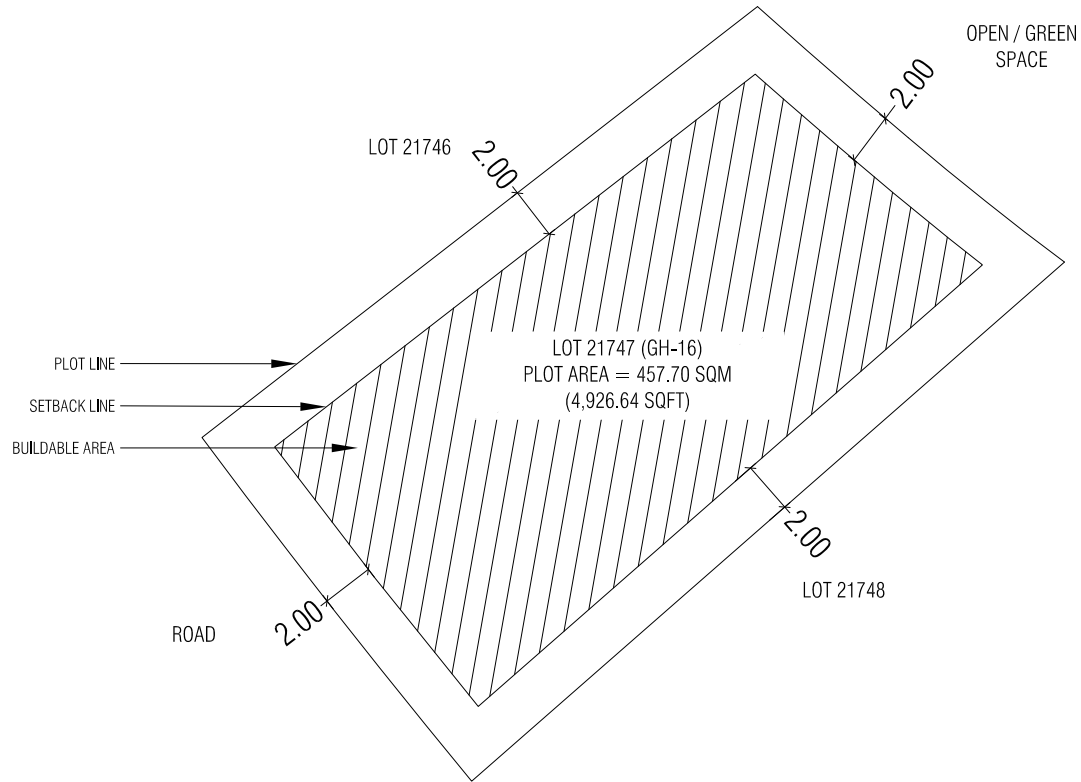

Lot Number	Description	Land Use	Plot Area	Foot Print	Gross Floor Area (G.F.A)	Plot Ratio (F.S.I)	Site Coverage	Max Height / Floors
21747	Guesthouse	Hotels & Guesthouses	457.70 SQM	320.39 SQM	2,082.54 SQM	4.6	70%	6 Floors / 22.5m
			4,926.64 SQFT	3,448.65 SQFT	22,416.20 SQFT			18.5m bldg + 4m Lift Machine Room

PROJECT: LOT 21747 (GH-16)

DRAWING: SETBACK PLAN

Scale: N.T.S

Drawn by: Mauman

Checked by:

Date: 5th November 2022

Remarks:

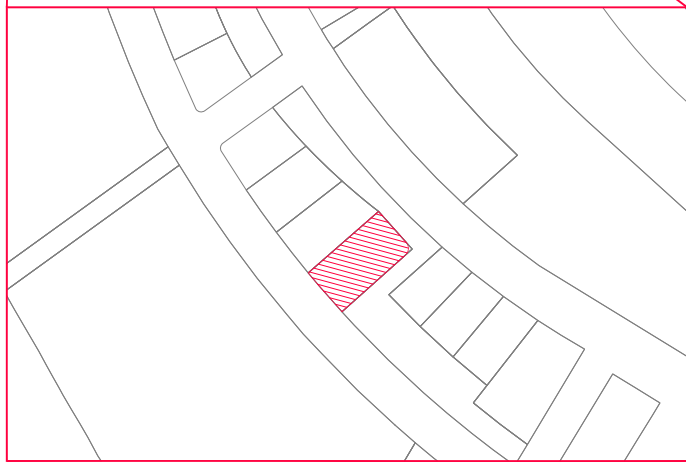
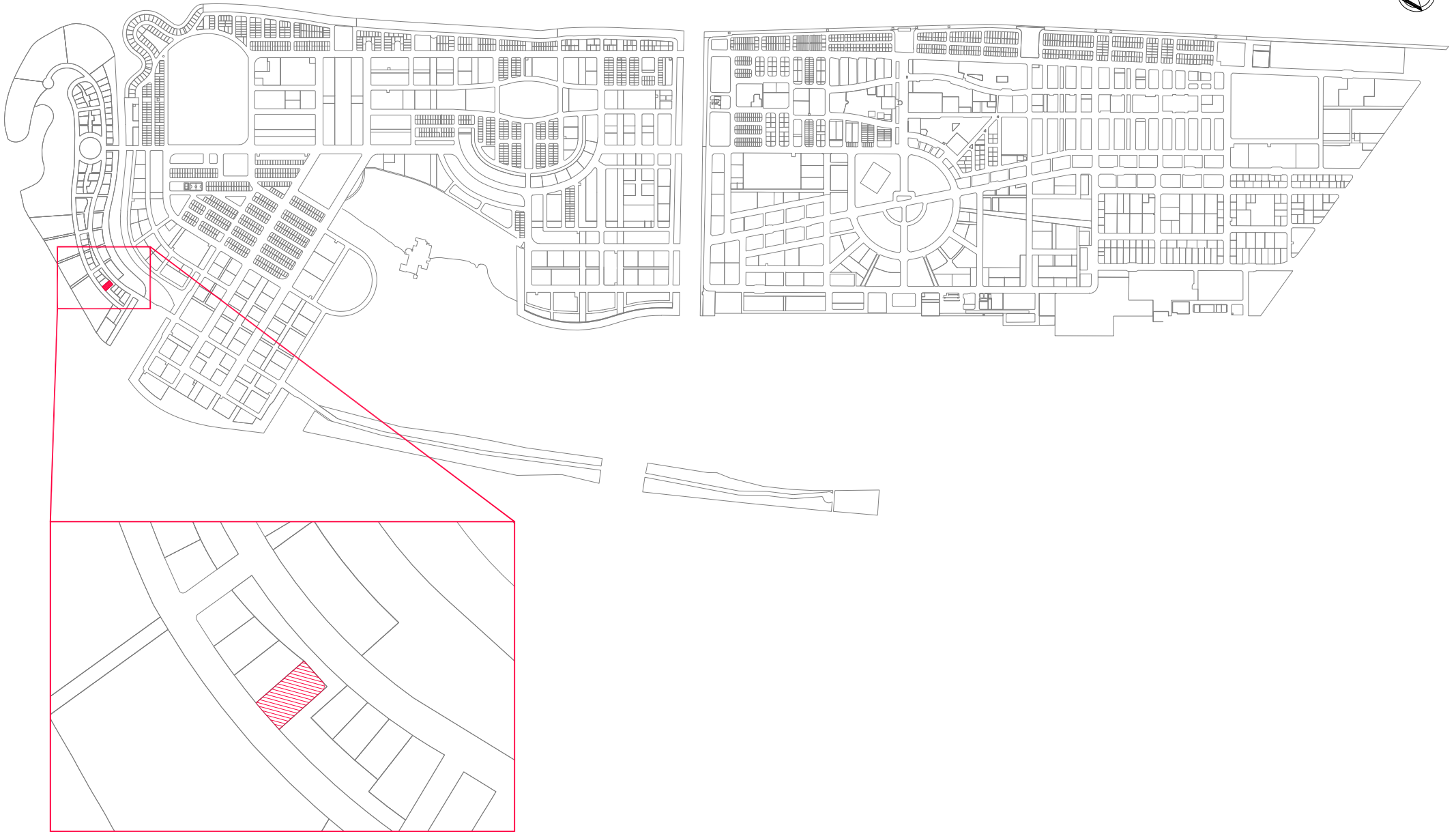

PROJECT: LOT 21748 (GH-17)

Scale: N.T.S

Drawn by: Thorif Ibrahim

Checked by: Mohamed Ibrahim

Date: 27th November 2022

DRAWING: LOCATION MAP

Remarks:



LEGEND:

* PROPOSED

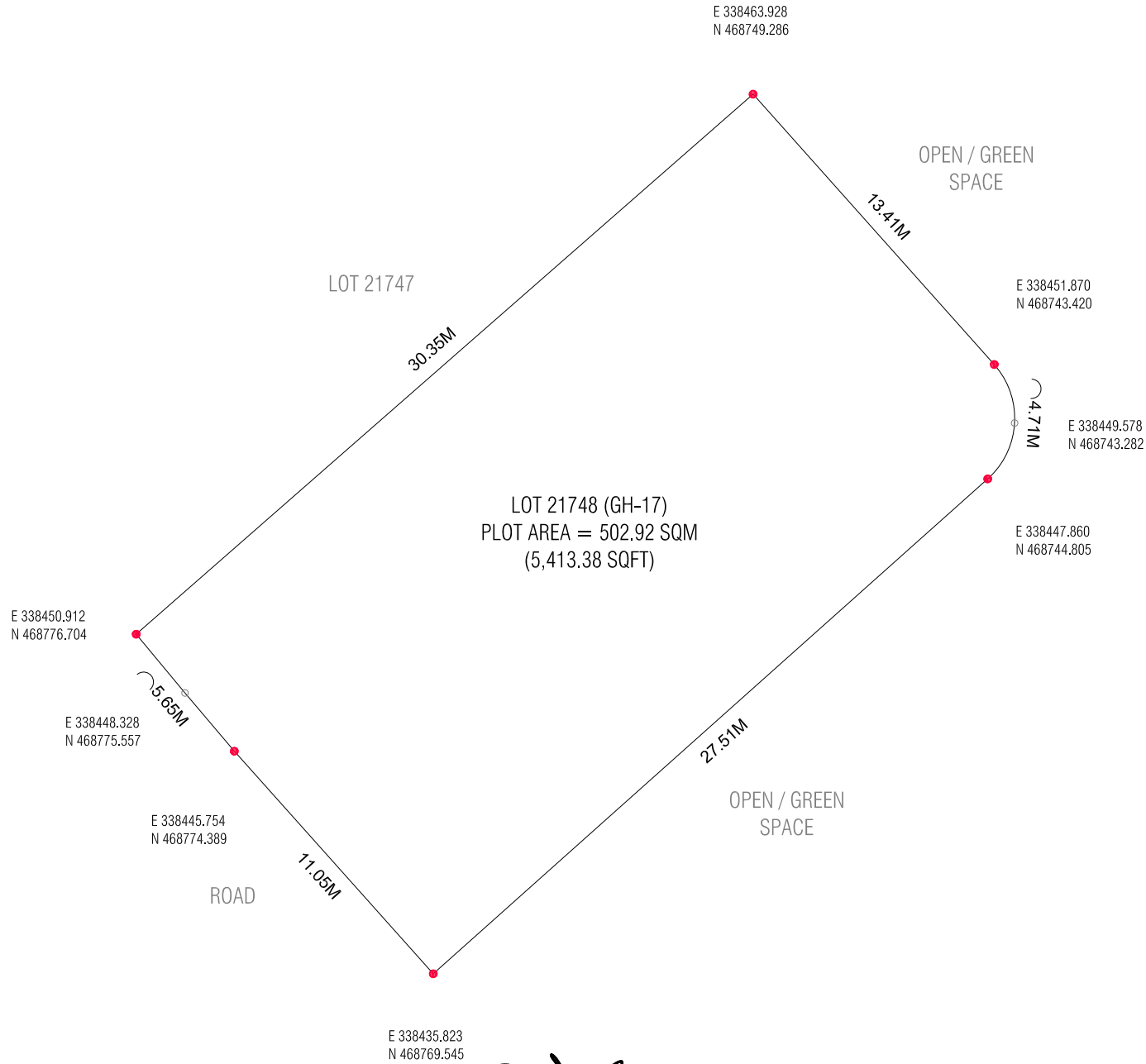

PROJECT: LOT 21748 (GH-17)

Scale: N.T.S

Drawn by: Thorif Ibrahim

Checked by: Mohamed Ibrahim

Date: 27th November 2022

Remarks:

DRAWING: PLOT MAP

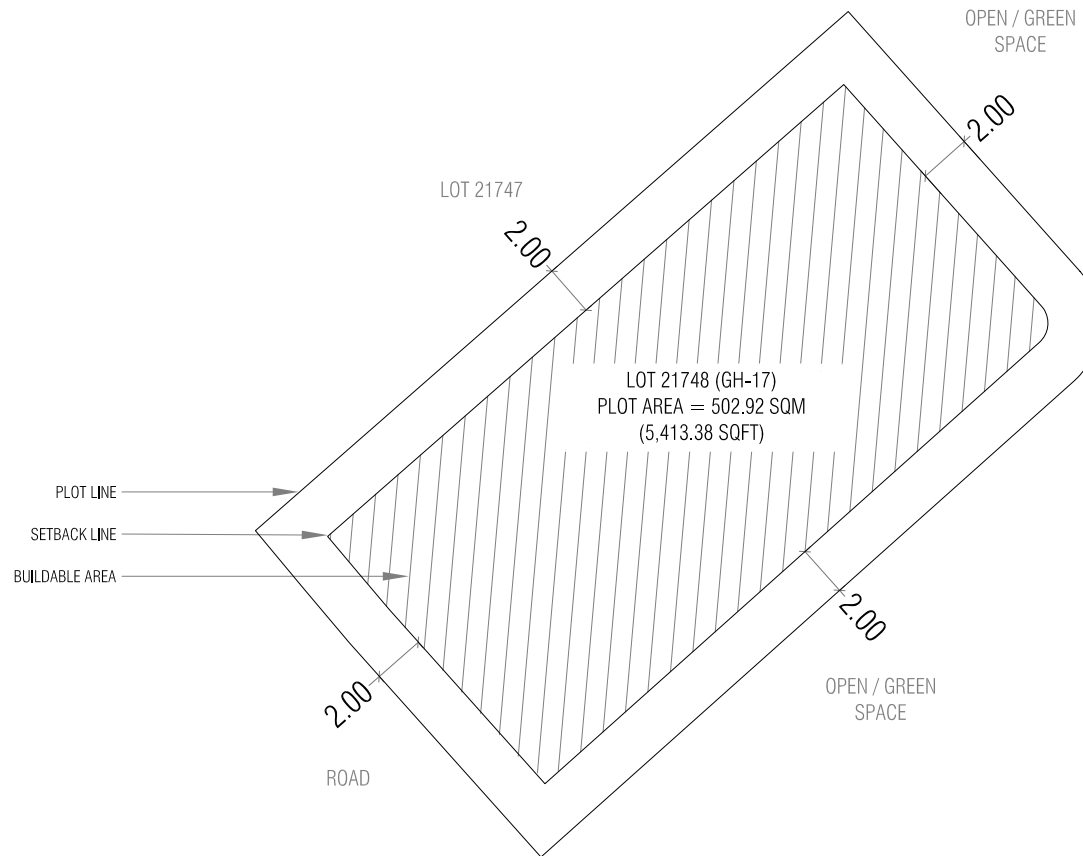

Lot Number	Description	Land Use	Plot Area	Foot Print	Gross Floor Area (G.F.A)	Plot Ratio (F.S.I)	Site Coverage	Max Height / Floors
21748	Guesthouse	Hotels & Guesthouses	502.92 SQM	352.04 SQM	2,288.29 SQM	4.6	70%	6 Floors / 22.5m
			5,413.38 SQFT	3,789.37 SQFT	24,630.88 SQFT			18.5m bldg + 4m Lift Machine Room

PROJECT: LOT 21748 (GH-17)

DRAWING: SETBACK PLAN

Scale: N.T.S

Drawn by: Mauman

Checked by:

Date: 5th November 2022

Remarks:

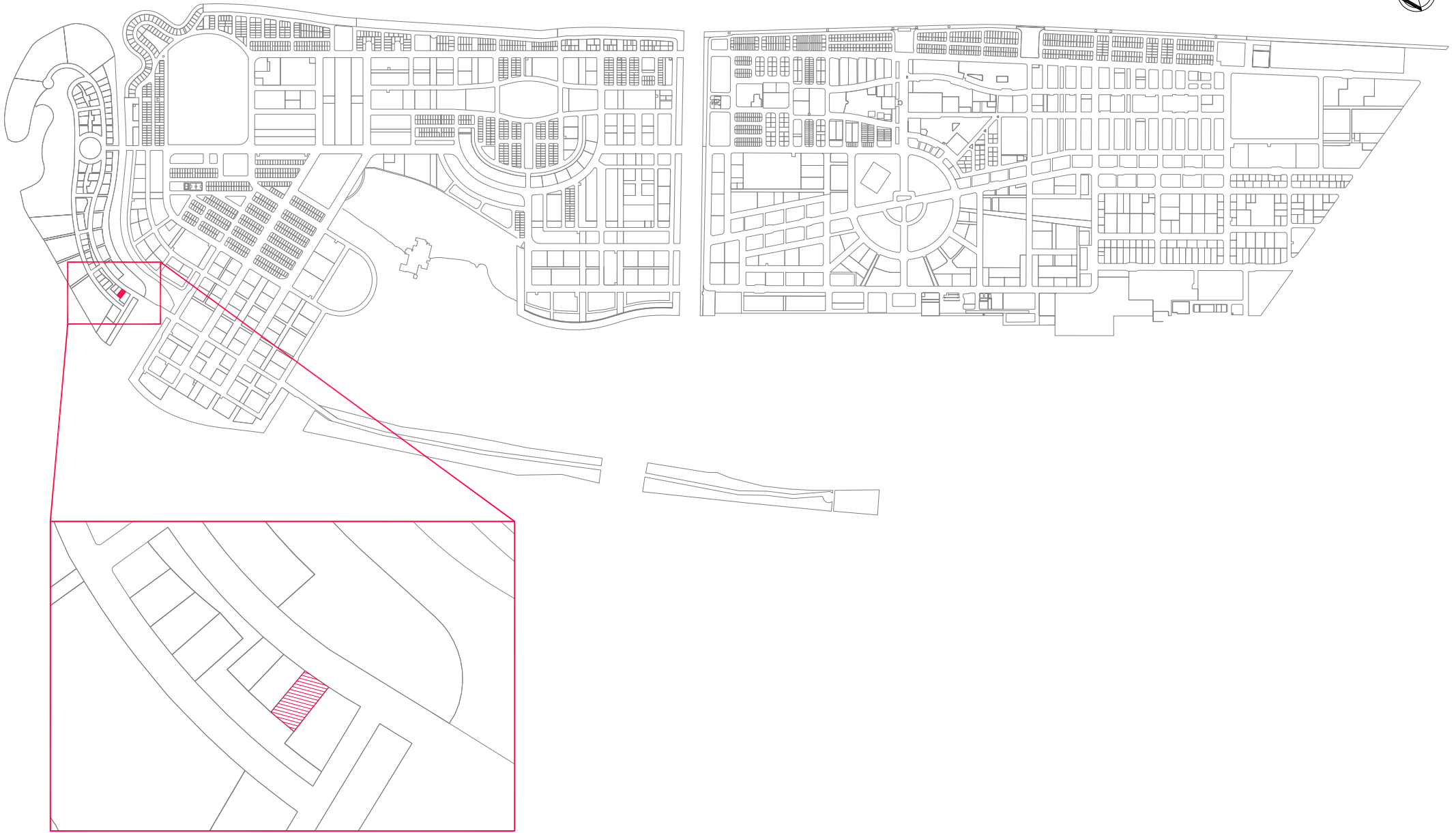

PROJECT: LOT 21751 (GH-20)

Scale: N.T.S

Drawn by: Thorif Ibrahim

Checked by: Mohamed Ibrahim

Date: 27th November 2022

DRAWING: LOCATION MAP

Remarks:

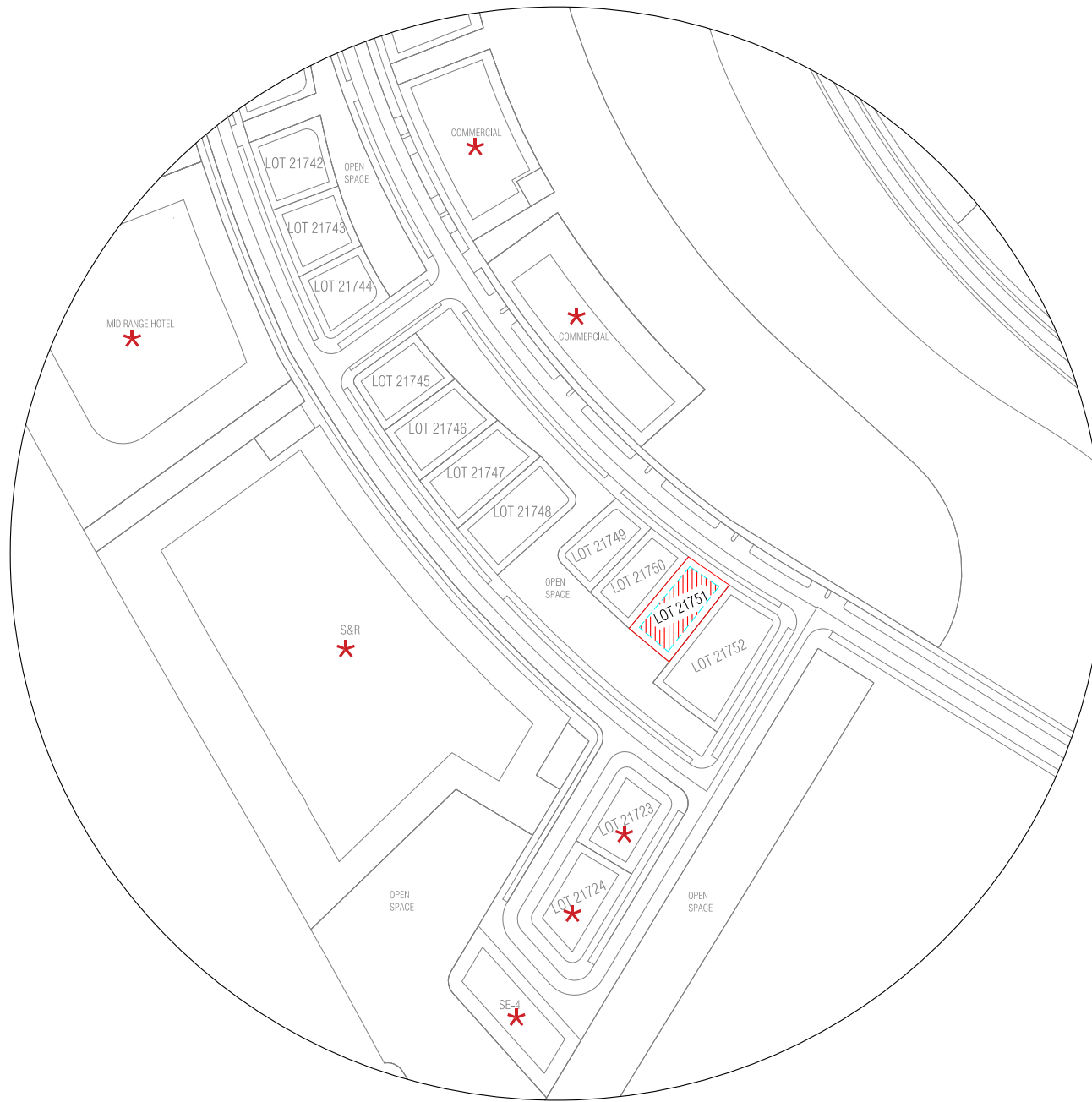

LEGEND:

* PROPOSED

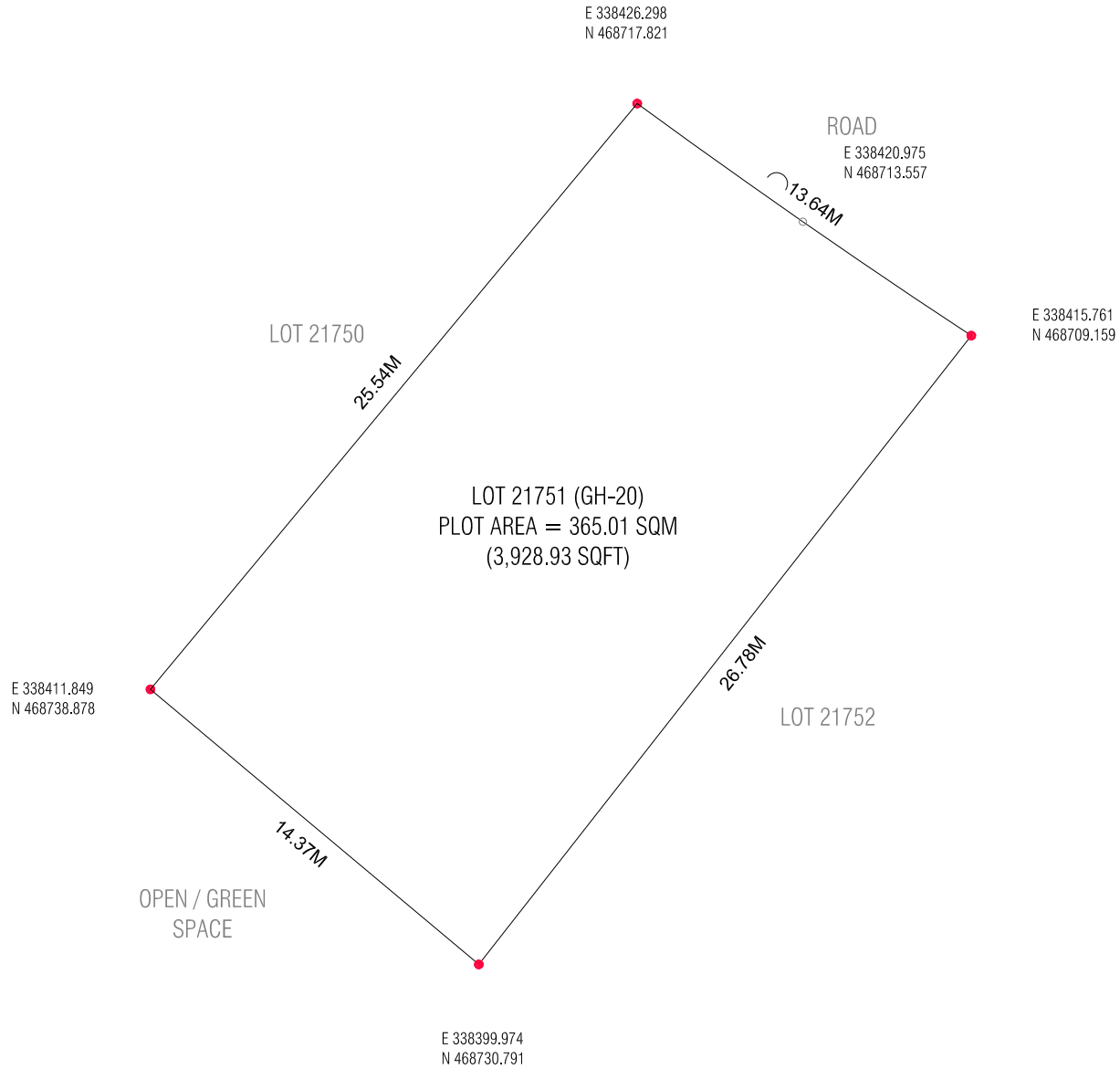

PROJECT: LOT 21751 (GH-20)

Scale: N.T.S

Drawn by: Thorif Ibrahim

Checked by: Mohamed Ibrahim

Date: 27th November 2022

Remarks:

DRAWING: PLOT MAP

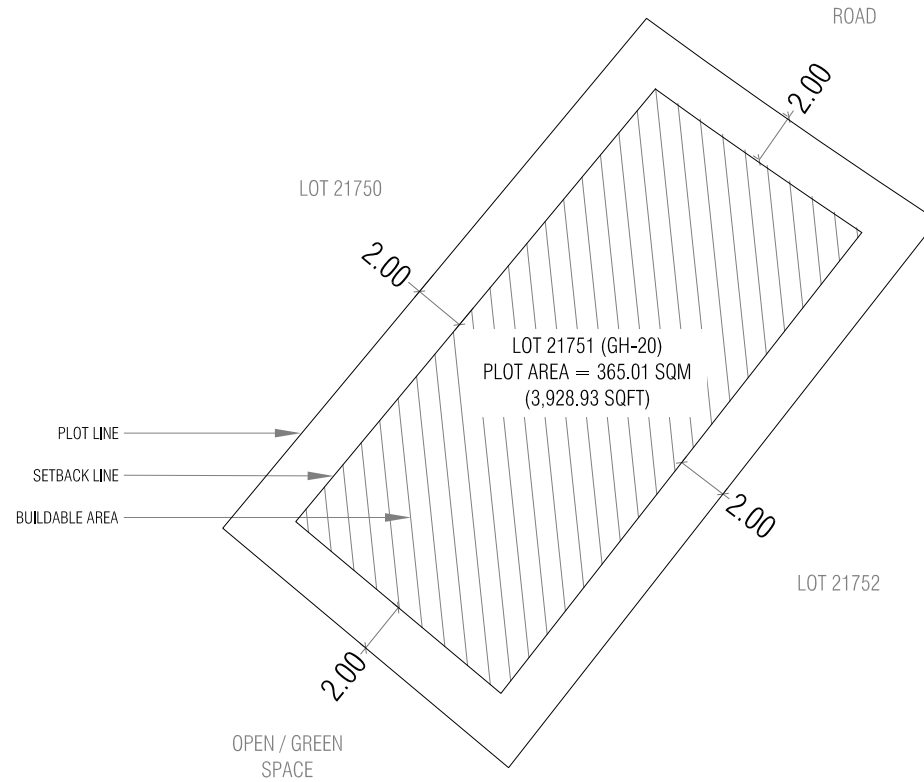

Lot Number	Description	Land Use	Plot Area	Foot Print	Gross Floor Area (G.F.A)	Plot Ratio (F.S.I)	Site Coverage	Max Height / Floors
21751	Guesthouse	Hotels & Guesthouses	365.01 SQM	255.51 SQM	1,660.80 SQM	4.6	70%	6 Floors / 22.5m
			3,928.93 SQFT	2,750.25 SQFT	17,876.64 SQFT			18.5m bldg + 4m Lift Machine Room